



# V410 C FI



## SCHEDA TECNICA RIASSUNTIVA TECHNICAL SUMMARY

Produzione oraria Kg <i>Hourly production Kg</i>	/
Produzione oraria LT <i>Hourly production LT</i>	/
Produzione minima ciclo LT <i>Minimum cycle production LT</i>	/
Produzione massima ciclo LT <i>Maximum cycle production LT</i>	/
Miscela introdotta ciclo Kg <i>Mixture introduced cycle Kg</i>	/
Miscela introdotta ciclo Lt <i>Mixture introduced cycle Lt</i>	/
Pastorizzazione ciclo <i>Pasteurization cycle</i>	/
Crema ciclo <i>Cream cycle</i>	/
Tensione standard <i>Standard voltage</i>	230V~50Hz 230V~50Hz
Potenza W <i>Power W</i>	200 200
Condensazione <i>Condensation</i>	A A
Dimensione nette mm L/P/H <i>Net dimension mm W/D/P</i>	495x495x620 495x495x620
Peso netto Kg <i>Weight Kg</i>	34 34

## DIMENSIONI (mm) DIMENSIONS (mm)

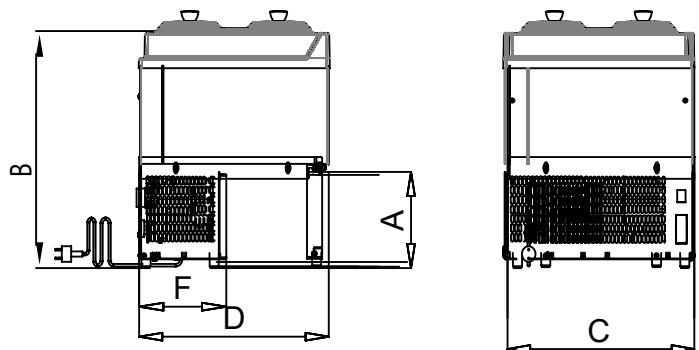

A	B	C	D	F	G	L	S	T	Z
240	658/588/616	495	491	215	1062				